

Guide to Global NDT CODES & STANDARDS

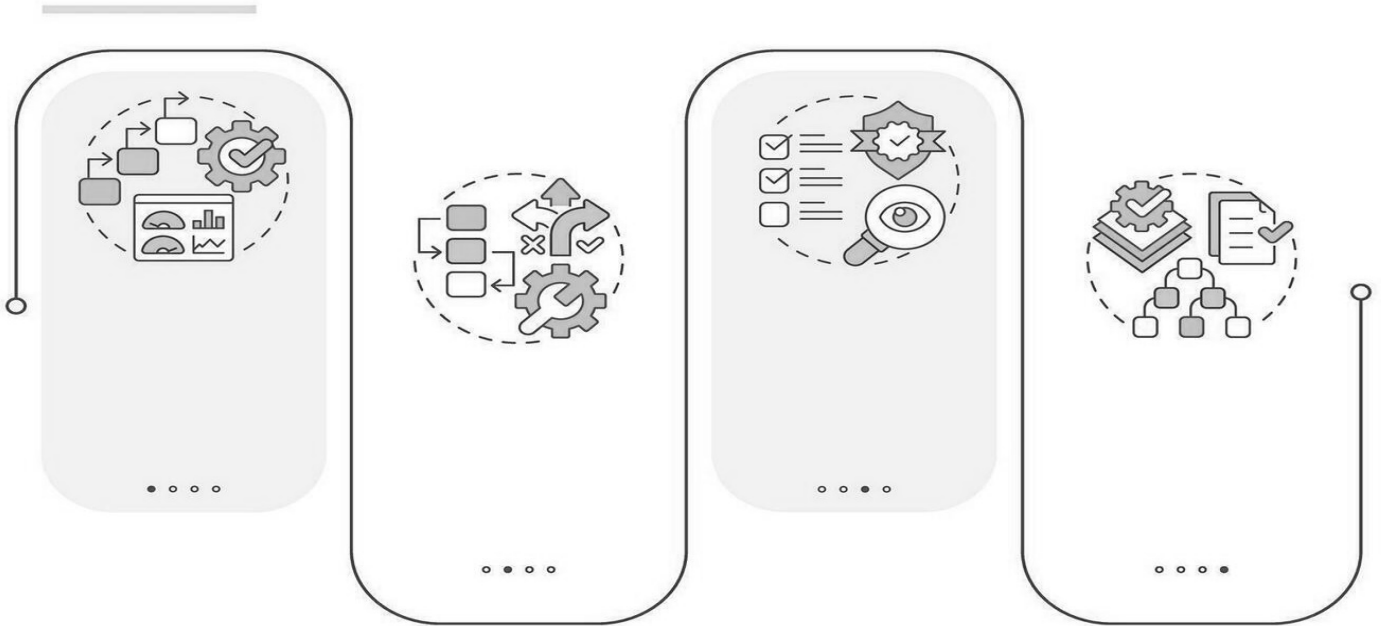

CODE

Code is a standard that has been adopted by one or more governmental bodies and has the force of law, or when it has been incorporated into a business contract.

- Codes are generally the governing documents, providing a set of rules that specify the minimum acceptable level of safety for manufactured, fabricated, or constructed objects.
- Most codes will provide acceptance and rejection criteria for the required inspections.
- ASME (American Society of Mechanical Engineers) Codes are legally enforceable in many US states. Whereas, in the other part of the world they are not legally enforceable, but such countries have their own similar codes.

Most countries have one or more organizations (“standards bodies”) that develop and publish technical industrial standards. Some do not, and those usually reference existing codes and standards for their manufacturing, fabrication, and construction projects. **In the United States**, these organizations are usually independent organizations from private industry, but in many countries, they are government.

STANDARD

Standards are documents that establish engineering or technical requirements for products, practices, methods, or operations.

- Standards are the documents, prepared by professional societies or committee, which are believed to be efficient engineering practices and which contain mandatory requirements.
- An inspection standard may include information on how to apply multiple testing techniques.
- Standardization of certain items to prevent multiple versions to be used.
- Standards are usually created by individual companies, organizations, or countries. They are not legalized.

Authorized Organizations

To create CODES & STANDARD

For Non-Destructive Testing

ASNT	(American Society of Non-Destructive Testing)
ASTM	(American Society for Testing & Materials)
ASME	(American Society for Mechanical Engineers)
API	(American Petroleum Institute)
AWS	(American Welding Institute)
AIA	(Aerospace Industries Association)
NBBI	(National Board of Boiler and PV Inspectors)
ISO	(International Organization for Standardization)
CEN	(European Committee for Standardization)
PED	(European Pressure Equipment Directive)

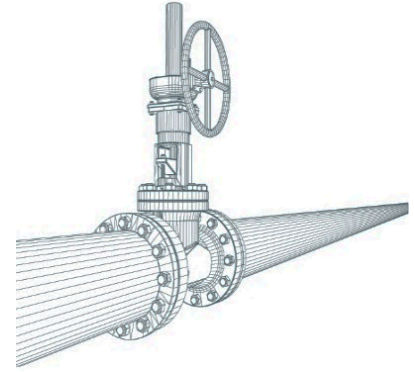

AUTHORIZED Organizations

For

TRAINING CERTIFICATION Non-Destructive Testing

American Society of Non-Destructive Testing (ASNT), a globally established organization, which offers NDT persons, a broad level of certification and training including all methods of NDT. ASNT offers, ASNT Level II, ASNT Level III.

British Institute of Non-destructive Testing (BINDT), an accredited certification organization that offers a Personnel Certification in Nondestructive Testing (PCN).

International Standards Organization (ISO), ISO 9712 (Non-destructive testing – Qualification and certification of NDT personnel) is a published standard that details the requirements for qualification and certification of personnel that perform NDT.

American Petroleum Institute (API), API offers numerous Individual Certification Programs (ICPs) specific to NDT personnel in the petroleum and petrochemical industries.

Natural Resources Canada (NRCan), NRCan manages the Non-Destructive Testing Certification Body (NDTCB), which offers a Canadian General Standards Board (CGSB) certification.

Another organization that can do it; French Committee for Non-destructive Testing Studies (COFREND), Canadian Standards Association (CSA Group), Canadian General Standards Board (CGSB)

The exact regulations designed to handle NDT vary by country and industry.

ASNT

THE AMERICAN SOCIETY FOR NONDESTRUCTIVE TESTING.

is a member-based, non-profit professional society.

Provides NDT related reference materials, technical conferences, and certification documents. ASNT does not publish standards that describe how to perform NDT tasks.

Those are published by ASTM International and are discussed in that section,

ASTM

ASTM International

(Formerly the American Society for Testing and Materials) is one of the largest voluntary standards development organizations in the world, providing technical standards for materials, products, systems, and services. Over 180 ASTM NDT standards are published in the ASTM Annual Book of Standards, Volume 03.03, and Non-destructive Testing. ASTM defines three of their document categories as follows:

A "GUIDE"

is a compendium of information or series of options that does not recommend a specific course of action. A guide increases the awareness of information and approaches in each subject area.

A "PRACTICE"

is a definitive set of instructions for performing one or more specific operations or functions that does not produce a test result. Examples of practices include, but are not limited to application, assessment, cleaning, collection, decontamination, inspection, installation, preparation, sampling, screening and training.

A "TEST METHOD"

is a definitive procedure that produces a test result. Examples of test methods include, but are not limited to identification, measurement and evaluation of one or more qualities, characteristics or properties.

Here are the most used ASTM NDT standards. Additional standards could be sourced in the ASTM Annual Book of Standards, Volume 03.03.

ASTM E709:	Standard Guide for Magnetic Particle Testing
ASTM E1444:	Standard Practice for Magnetic Particle Testing for Aerospace
ASTM E165:	Standard Practice for Liquid PT for General Industry
ASTM E1417:	Standard Practice for Liquid Penetrant Testing
ASTM E1208:	Standard Practice for PT using the Lipophilic Post-Emulsifiable
ASTM E1209:	Standard Practice for PT using the Water-Washable Process
ASTM E1210:	Standard Practice for PT using the Hydrophilic Post-Emulsifiable
ASTM E1219:	Standard Practice for PT using the Solvent-Removable Process
ASTM E114:	Practice for UT Pulse-Echo Straight-Beam by the Contact Method
ASTM E164:	Standard Practice for Contact Ultrasonic Testing of Weldments
ASTM E213:	Standard Practice for Ultrasonic Testing of Metal Pipe and Tubing
ASTM E2375:	Standard Practice for Ultrasonic Testing of Wrought Products
ASTM E94:	Guide for Radiographic Examination
ASTM E1742:	Practice for Radiographic Examination
ASTM E1000:	Guide for Radioscopy
ASTM E1255:	Practice for Radioscopy
ASTM E1030:	Test Method for Radiographic Examination of Metallic Castings
ASTM E1032:	Test Method for Radiographic Examination of Weldments
ASTM E999:	Guide for Controlling the Quality of Industrial RT Film Processing
ASTM E142:	Method for Controlling Quality of Radiographic Testing
ASTM E2007:	Standard Guide for Computed Radiography
ASTM E2738:	Standard Practice for Digital Imaging for Computed RT (CR) Test
ASTM E268:	Electromagnetic testing
ASTM E1962:	Standard Practice for UT Surface Testing using (EMAT) Techniques
ASTM E426:	Practice for Electromagnetic (Eddy-Current) of Seamless and Welded Tubular Products, Austenitic Stainless Steel and Similar.

www.astm.org

ASME

AMERICAN SOCIETY OF MECHANICAL ENGINEERS

is a not-for-profit professional organization that enables collaboration, knowledge sharing and skill development across all engineering disciplines, while promoting the vital role of the engineer in society. ASME codes and standards, publications, conferences, continuing education, and professional development programs provide a foundation for advancing technical knowledge and a safer world. ASME publishes multiple codes and standards including (but not limited to) the following documents:

The "ASME Boiler & Pressure Vessel Code" (BPVC). The 2010 edition of the BPVC with 2011 addenda was made available in July 2011. This code is made up of 12 sections, or "books," covering the following subjects:

The BPVC is now published biennially in odd-numbered years without addenda in the intervening year.

API

AMERICAN PETROLEUM INSTITUTE

is a national trade association that represents all aspects of America's oil and natural gas industry, including producers, refiners, suppliers, pipeline operators, marine transporters and service and supply companies. Among the standards that API publishes are the following:

AWS

AMERICAN WELDING SOCIETY

is a nonprofit organization with the goal of advancing the science, technology, and application of welding and related joining disciplines. AWS provides certification programs for welding inspectors, supervisors, educators, etc., and publishes multiple standards, many of which contain procedures for the application of nondestructive testing methods and techniques above and beyond visual inspection. A few of their standards are listed here:

ASME# Sec. 1: Power Boilers

ASME# Sec. 2: Materials

ASME# Sec. 3: Rules for Construction of Nuclear Facility Components

ASME# Sec. 4: Heating Boilers

ASME# Sec. 5: Nondestructive Examination

ASME# Sec. 6: Recommended Rules for the Care & Operation of Heating Boilers

ASME# Sec. 7: Recommended Guidelines for the Care of Power Boilers

ASME# Sec. 8: Pressure Vessels

ASME# Sec. 9: Welding and Brazing Qualifications

ASME# Sec. 10: Fiber-Reinforced Plastic Pressure Vessels

ASME# Sec. 11: Rules for In-service Inspection of Nuclear Power Plant

ASME# Sec. 12: Rules for Construction and Continued Service of Transport Tanks

ASME B31.1: Power Piping. This code contains requirements for piping systems typically found in electric power-generating stations, industrial institutional plants, geothermal heating systems, and heating and cooling systems.

ASME B31.3: Process Piping. This Code contains requirements for piping typically found in petroleum refineries; chemical, pharmaceutical, textile, paper, semiconductor, and cryogenic plants; and related processing-plant terminals.

www.asme.org

API 510: Pressure Vessel Inspection: In-Service Inspection, Rating, Repair and Alteration

API 570: Piping Inspection: In-service Inspection, Rating, Repair, and Alteration of Piping Systems

API 650: Welded Tanks for Oil Storage

API 653: Tank Inspection, Repair, Alteration, and Reconstruction

API 1104: Welding of Pipelines and Related Facilities

www.api.org

AWS D1.1: Structural Welding Code - Steel

AWS D1.2: Structural Welding Code - Aluminum

AWS D1.3: Structural Welding Code - Sheet Steel

AWS D1.5: Bridge Welding Code

AWS D1.6: Structural Welding Code - Stainless Steel

www.aws.org

ISO

INTERNATIONAL ORGANIZATION FOR STANDARDIZATION

the world's largest developer and publisher of International Standards, is a non-governmental organization located in Geneva, Switzerland. ISO is a network of the national standards institutes of 161 countries, one member per country. Many of the ISO member institutes are part of the governmental structure of their countries or are mandated by their government. Other members have their roots uniquely in the private sector, having been set up by national partnerships of industry associations. Three of the many ISO standards are listed below:

AIA

AEROSPACE INDUSTRIES ASSOCIATION

is a trade association with more than 100 major aerospace and defense member companies. These companies embody every high-technology manufacturing segment of the U.S. aerospace and defense industry from commercial aviation and avionics to manned and unmanned defense systems, to space technologies and satellite communications.

CEN

EUROPEAN COMMITTEE FOR STANDARDIZATION

is a business facilitator in Europe, removing trade barriers for European industry and consumers. Its mission is to foster the European economy in global trading, the welfare of European citizens and the environment. CEN is a major provider of European Standards and technical specifications. It is the only recognized European organization according to Directive 98/34/EC for the planning, drafting and adoption of European Standards in all areas of economic activity except for electro-technology and telecommunication. CEN's 31 National Members work together to develop voluntary European Standards (ENs).

Standards (Norms) developed by CEN are considered "harmonized standards" that are required to be accepted by all member nations in the European Union. The following two ENs are NDT certification standards:

ISO 9712, Non-destructive testing - Qualification and certification of personnel.

This International standard, which was revised in 2012, provides the requirements for the NDT certification of NDT personnel by an accredited third-party certification body that conforms to the requirements of ISO/IEC 17024, Conformity assessment - General requirements for bodies operating certification of persons.

ISO/IEC 17024, Conformity assessment - General requirements for bodies operating certification of persons.

This international standard was developed with the objective of achieving and promoting a globally accepted benchmark for organizations operating certification of persons.

ISO/IEC 17011, Conformity assessment - General requirements for accreditation bodies accrediting conformity assessment bodies.

This international standard specifies the general requirements for accreditation bodies. ANSI, the U.S. accreditation body that has accredited ASNT is accredited under ISO 17011 and is a member of the International Accreditation Forum (IAF), the world association of Conformity Assessment Accreditation Bodies in the fields of management systems, products, services, personnel, and other similar programs of conformity assessment.

www.iso.org

NAS 410, NAS Certification & Qualification of Nondestructive Test Personnel. This employer-based certification standard establishes the minimum requirements for the qualification and certification of personnel performing nondestructive testing (NDT), nondestructive inspection (NDI), or nondestructive evaluation (NDE) in the aerospace manufacturing, service, maintenance, and overhaul industries. In 2002, NAS 410 was harmonized with European Norm 4179 (listed in the CEN section), so that the requirements in both documents are identical.

NAS 999, Nondestructive Inspection of Advanced Composite Structures. This specification establishes the requirements for non-destructive inspection (NDI), NDI standards, NDI methods, and NDI acceptance criteria.

www.aia-aerospace.org

EN 4179, Aerospace series - Qualification and approval of personnel for non-destructive testing. This employer-based certification standard is the European version of NAS 410, which was described under the Aerospace Industries Association section on this web page.

EN 473, Non-destructive testing - Qualification and certification of NDT personnel - General principles. This European Standard established principles for the third-party ("central") qualification and certification of personnel who perform industrial non-destructive testing (NDT) by an accredited third-party certification body. Under EN 473, certification bodies had to administer procedures for certification according to the requirements of EN 473 and must fulfill the requirements of EN ISO/IEC 17024.

EN ISO 9712, which was approved in June 2012, replaced EN 473 as the European harmonized standard (Norm) for NDT central certification effective 1 January 2012. EN ISO 9712 permits the use of current EN 473 certifications until the certificate holders' next renewal period, at which time they must recertify in accordance with the EN ISO 9712 requirements. EN ISO 9712 and ISO 9712 are identical except that EN ISO 9712 has been approved as a harmonized standard for use under the European Pressure Equipment Directive 97/23/EC.

www.cen.eu